

The Public Notices are hereby given that the following information is being published for public review and comment. The information is being published for public review and comment. The information is being published for public review and comment.

Prepared by: Jorgensen & Associates, Inc.

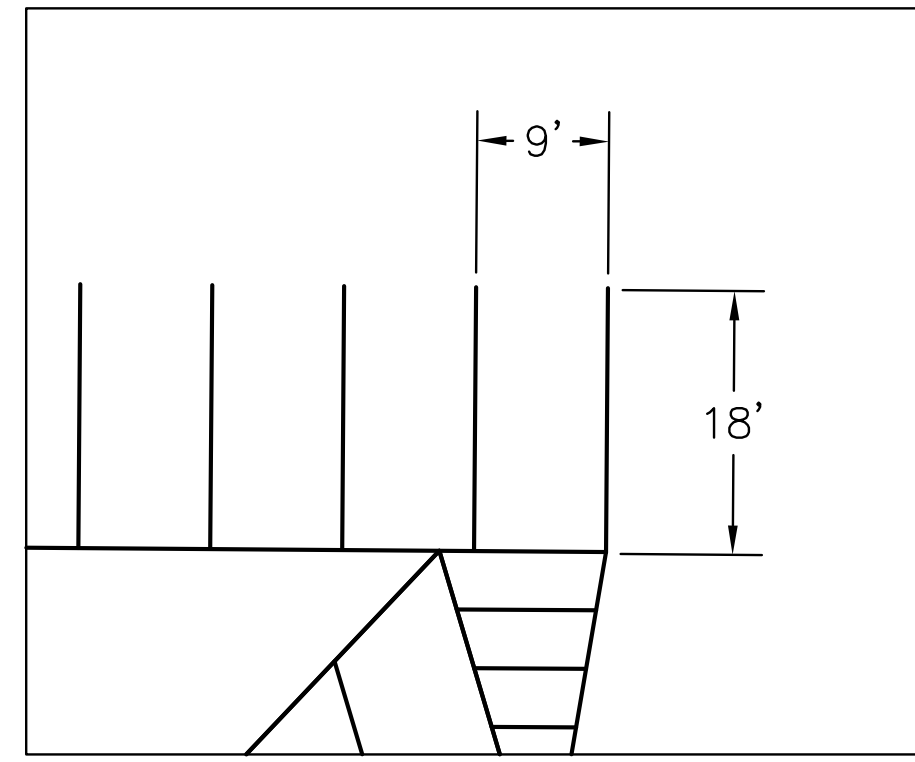

TYPICAL PARKING STALL LAYOUT

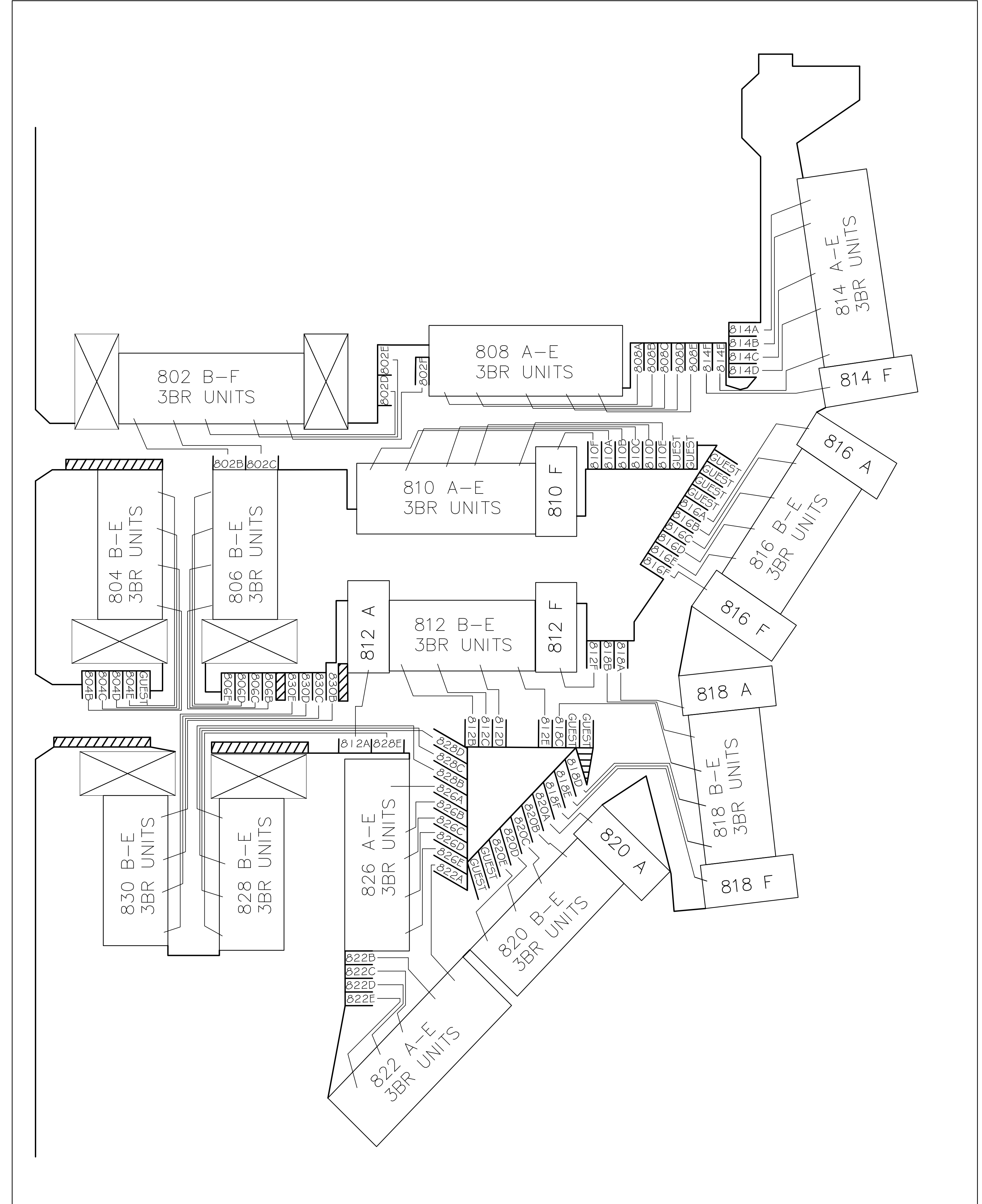
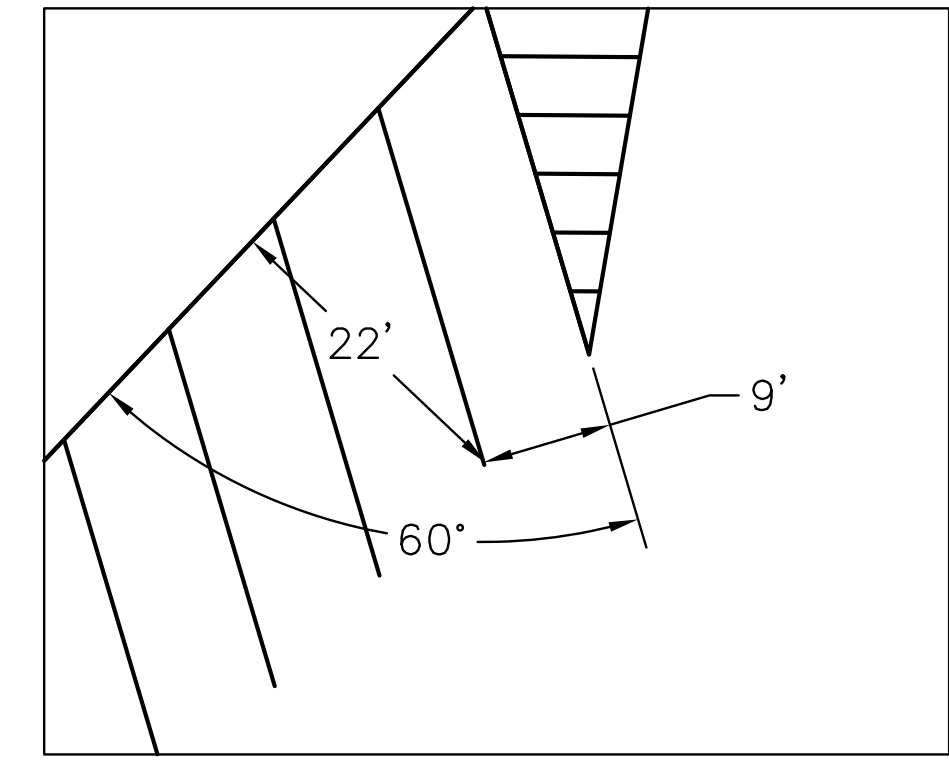

TYPICAL ANGLED PARKING STALL LAYOUT

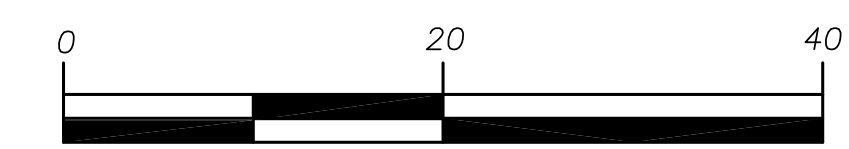
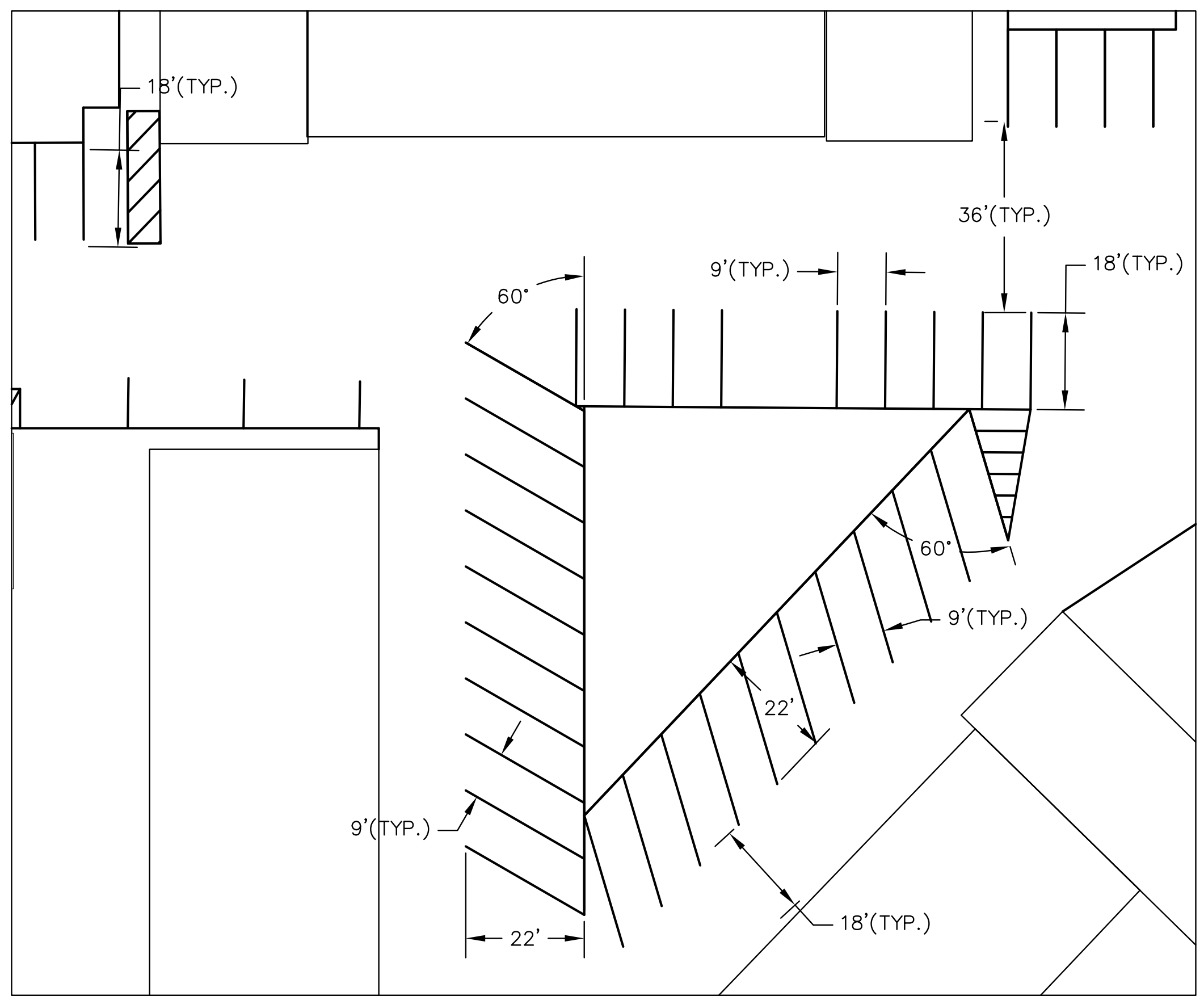

Scale: 1 Inch = 20 Feet
 This scale valid only for 22x34 prints.

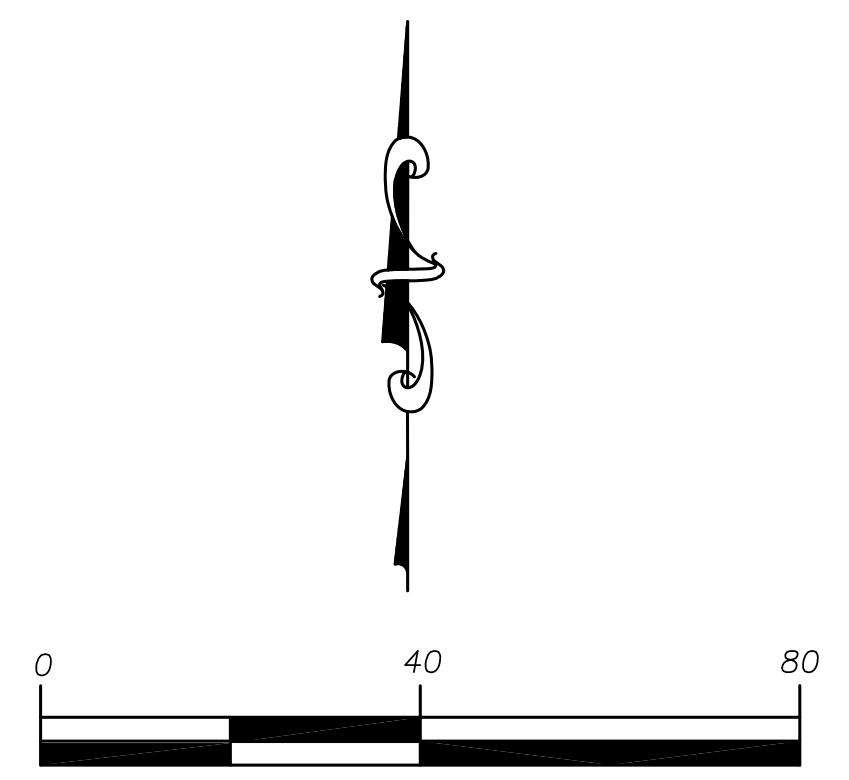

Scale: 1 Inch = 40 Feet
 This scale valid only for 22x34 prints.

- NOTES:
- TOTAL STALLS: 80
 - TYPICAL STALL SIZE: 9'x18'

- PRELIMINARY -
 SUBJECT TO CORRECTION
 AND APPROVAL



PROJECT TITLE:
 GRAND TETON PROP MGMT
 CREEKSIDE VILLAGE
 802 POWDERHORN LANE
 JACKSON, WYOMING

SHEET TITLE:
 PARKING PLAN
 OVERVIEW

DRAFTED BY:	MC
REVIEWED BY:	TK
PLAN VERSION	DATE
UPDATE EXST COND.	12/22/2016
PARKING ASSIGN.	5/23/2017
PARKING REVISION	7/25/2017

PROJECT NUMBER
 16032
 SHEET
 P1